

HEAVY DUTY CHAIN HOIST MODEL : HDCH A619

Technical information:

- Each hoist is made with high performance materials for extra durability.
- Black Color finish with high strength steel frame.
- Meets the WLL performance requirements of BS EN 13157.
- Minimum break load 4 times the WLL.
- Grade 80 (T - Fine tolerance calibrated) load chain, meets the WLL performance requirements of BSEN 818-7.
- Spur gear efficiency reduces operator effort, Double guide rollers enhance performance, safety and reliability
- Top and bottom hooks with heavy duty cast catches.
- Over load protection system.
- Mill Test Certificate Available.

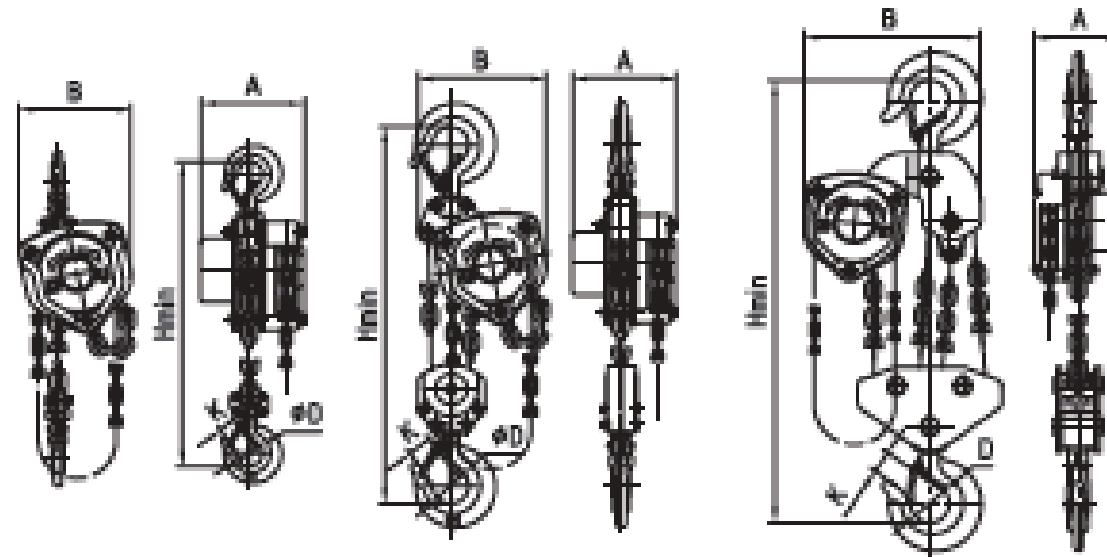

0.5t\1t\1.5t\2t

3t\5t

10t

TECHNICAL SPECIFICATION	Product Code	Capacity	A	B	D	Hmin
		(Kgs)	(mm)	(mm)	(mm)	(mm)
	HDCH 61900500	500	137.5	137	34	270
	HDCH 619001000	1,000	146.5	162	40	340
	HDCH 619001500	1,500	170	183	46	399
	HDCH 619002000	2,000	170	194	50	419
	HDCH 619003000	3,000	190.4	220	55	512
	HDCH 619005000	5,000	190	288	66	625
	HDCH 6190010000	10,000	209	384	86	748
	HDCH 6190020000	20,000	312	625	110	890
	HDCH 6190030000	30,000	406	691	110	1380

TECHNICAL SPECIFICATION	Capacity	Elongation @ max load	Load chain Diameter	Load Chain Falls	Net weight (kg) with 3m Load chain
	(Kgs)	(%)	(mm)		
	500	200	6	1	87
	1000	320	6	1	108
	1500	360	8	1	152
	2000	365	8	1	18
	3000	385	8	2	245
	5000	435	10	2	366
	10000	435	10	4	78
	20000	435x2	10	8	164
	30000	435x2	10	12	230